



National Truck Protection®

NEW

PREFERRED WARRANTY PROGRAM

**EXCLUSIVELY FOR
OWNER OPERATORS OF**

United  **Road**

Driven to deliver.





Want Peace of Mind? Get the **NEW PREFERRED** Warranty Program

EXCLUSIVELY FOR UNITED ROAD OO'S

Since 1983, NTP® has provided coverage for major equipment failure on engine, aftertreatment, turbo's, injectors, transmission, water pumps and more. Having coverage when equipment fails gives you peace of mind that NTP will take care of covered repairs so you're back on the road quickly and safely.

An Affordable and Smart Way to Protect Your Business

The NTP *PREFERRED* warranty is affordable and easy to manage. You choose the program that's best for you and the premiums are deducted each month from your settlement or pay each month. So for as little as about \$30/month you can protect your business, your livelihood, from an unexpected equipment failure that could cost you thousands of out of pocket dollars to make those repairs. So, don't take that risk. Pick the program that's right for you and drive with peace of mind.

BENEFITS OF INVESTING IN AN NTP WARRANTY:

- **Peace of Mind:** If you bought the coverage, you're covered.
- **Financial Protection:** Expensive repairs don't have to come out of your pocket.
- **Essential Coverage:** Know that major equipment is covered when failure occurs.
- **We Pay Claims:** If you're covered, we'll pay for the repair. In fact, we pay tens of millions of dollars in claims every year.
- **Reliable Customer Service:** Call, email or use your online portal for questions or to submit claims.

Protect Your Truck for \$123 / Month

Truck Monthly Rates

Covered Components	10 years old or newer from current year		More than 10 years old from current year	
	12 months/ 100K Miles	24 months/ 200K Miles	12 months/ 100K Miles	24 months/ 200K Miles
Engine, Trans, Rears	\$148/mo	\$123/mo	\$211/mo	\$165/mo
Engine, Trans, Rears, Critical Components	\$243	\$203	\$306	\$245
Engine, Trans, Rears, Critical Components, Aftertreatment	\$343	\$273	N/A	N/A
Comfort Package	\$44	\$29	\$44	\$29

Critical Components Include turbos, fuel injectors, fuel pump, water pump, ECM.
Comfort Package must be purchased with an equipment warranty program.

Protect Your Trailer for About \$88 / Month

Trailer Monthly Rates

12 Months / 100k Miles	8 + Car Haulers			
	2011 and Newer		2010 and Older	
	High Rail	Quick Loader	High Rail	Quick Loader
	\$241.58	\$166.58	\$289.90	\$199.90
24 Months / 200k Miles	8 + Car Haulers			
	2011 and Newer		2010 and Older	
	High Rail	Quick Loader	High Rail	Quick Loader
	\$181.21	\$124.96	\$217.46	\$149.96
24 Months / 200k Miles	1-7 Car Haulers			
	2011 and Newer		2010 and Older	
	High Rail	Quick Loader	High Rail	Quick Loader
	\$126.85	\$87.47	\$152.22	\$104.97

Trailer warranty must be purchased with a vehicle warranty program.
See new *PREFERRED* coverage details on back

Major Components Repair Costs Range

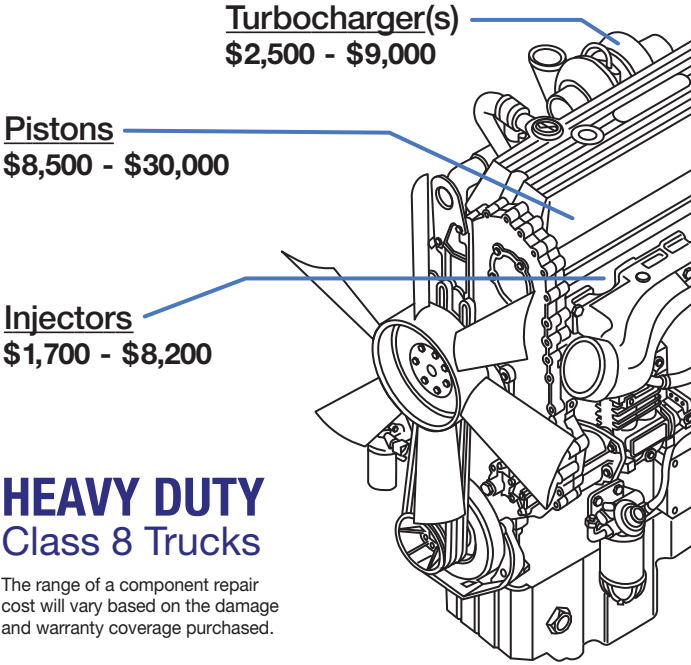

High Risk of Equipment Failure After Factory Warranty Ends

Example of Basic Warranty Coverage for New HD/MD Trucks

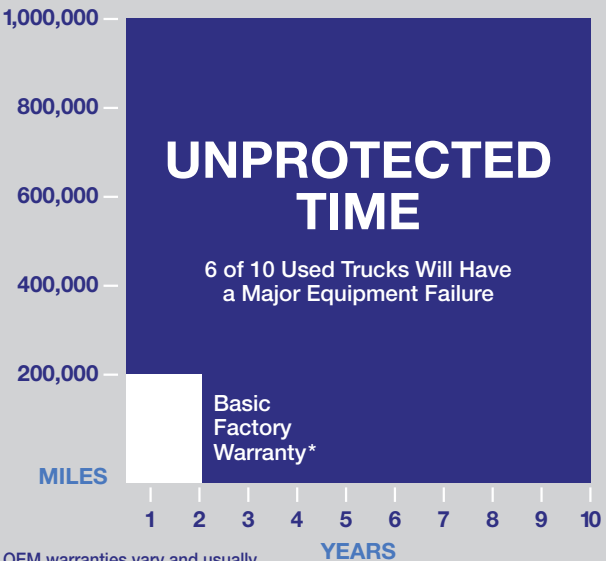

* Basic OEM warranties vary and usually include engine and sometimes transmission.

Source: internal claims data

The high cost to repair one major equipment failure could put your business in jeopardy. A National Truck Protection warranty will protect your business, your investment and your livelihood.

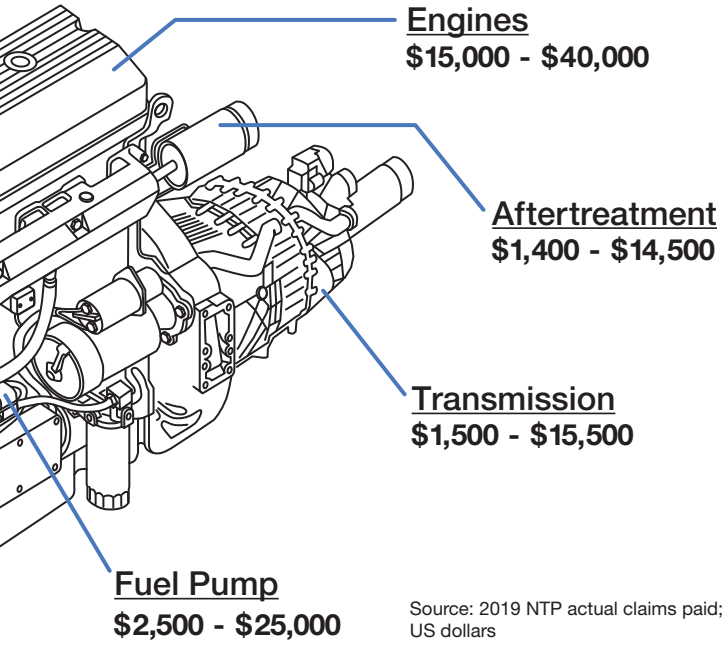

Cost of Repairs for Claims Paid

- 50% of paid claims have repair costs over \$5,000
- More than 1 in 5 claims had repair costs over \$10,000

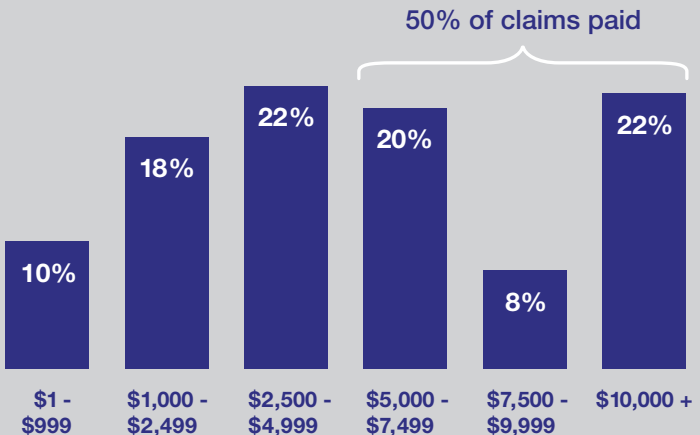

Source: 2019 NTP claims data.

NTP *PREFERRED* Warranty Program

Covered Components

Engine (LOL \$22,500)

Engine's internally lubricated hard parts:

- Camshaft and Cam Bearings
- Cam Followers
- Connecting Rods
- Connecting Rod Bearings
- Connecting Rod Caps and Screws
- Crankshaft
- Cylinder Block Casting
- Cylinder Head
- Cylinder Head Gasket
- Cylinder Liners
- Cylinder Head Bolts
- Hydraulic Lifters
- Injector Cups
- Intake and Exhaust Valves
- Intake and Exhaust Valve Guides
- Main Bearings
- Oil Cooler and Housing
- Oil Pan
- Oil Pump Pick Up Screen
- Oil Pump Pick Up Tube*
- Oil Pump Pressure Relief Springs and Valves
- Pistons, Piston Rings and Piston Oil Cooling Jets
- Pushrods
- Rocker Arms and Rocker Arm Shafts
- Thrust Washers
- Timing Gears
- Timing Gear Cover and Housing
- Valve Cover
- Valve Retainers and Keepers (Locks)
- Valve Seats
- Valve Springs
- Wrist Pins

"Non-oil" related components:

- Exhaust Manifold
- Flywheel Housing
- Intake Manifold
- Thermostat Housing
- Vibration Dampener

* For Detroit Diesels, breakdowns originating from the "oil pump pick up tube O-ring" will only be covered if the TSB D18M3 has been performed by a certified OEM repair shop.

Transmission (LOL \$7,500)

Internally lubricated hard parts of the manual or automatic transmission include:

- Bands
- Bearings
- Blockers
- Bushings
- Drums
- Gear Sets
- Governor
- Oil Pump
- Shaft(s)
- Shift Forks
- Synchronizers
- Thrust Washers
- Torque Converter
- Valve Body

CLASS 8, up to 10 years including the current calendar year; start miles <900,000 miles; warranty expires at 1,000,000 total miles. All costs are in US dollars.

CC = Included in Critical Components
LOL = Limits of Liability

Differential (LOL \$7,500)

Internally lubricated hard parts include:

- Axle Housing
- Axle Shafts
- Bearings
- Bushings
- Carrier Case
- Gear Sets
- Limited Slip Clutch Pack

Power divider includes:

- Bearings
- Gears
- Shafts
- Shift Forks

(CC) Turbo (LOL \$7,500)

Turbochargers include:

- Bearings
- Internal Variable Vane Assembly
- Turbine and Turbine Shaft
- Turbo Actuator

(CC) Engine Fuel Injectors, Water Pump, Fuel Pump & ECM (LOL \$5,000)

- Complete Injector
- Fuel Injector Hard Lines
- Fuel Injection Pump
- Fuel Pump
- Engine Control Module (ECM)
- Water Pump

Progressive Damage, Wearout & Carbon Packing

Please refer to your contract for details on Progressive Damage, Wearout & Carbon Packing coverage.

Aftertreatment, Model Year 2014 & Older (LOL \$7,000)

- Aftertreatment Electronic Control Module (ACM)
- Diesel Exhaust Fluid (DEF) Module with Injection Nozzle
- DEF Tank
- Diesel Oxidation Catalyst (DOC)
- DOC Doser Injector
- Diesel Particulate Filter (DPF)
- DPF Dosing Module
- Exhaust Gas Recirculation (EGR) Valves
- EGR Cooler(s)
- Hydrocarbon Doser Injector (HC Doser, 7th Injector, ARD, AHI Module)
- Selective Catalytic Reduction (SCR) Catalyst
- Sensor, Lambda (O₂ Sensor)
- Sensor, NO_x (2)

Coverage Exclusions: Please refer to your contract for complete list and details of covered and non-covered items.

Aftertreatment, Model Year 2015 & Newer (LOL \$8,000)

- Aftertreatment Electronic Control Module (ACM)
- Back Pressure Control Valve (BPV)
- Diesel Exhaust Fluid (DEF) Module with Injection Nozzle
- DEF Heater Control Relay
- DEF Dosing Module - Wiring Harness
- DEF Heated Lines (3)
- DEF Heater Coolant Control Valve
- DEF Heating Elements
- DEF Heating Fittings (3 on Supply Module)
- DEF Pump and Module
- DEF Solution Level/Temperature Sensor
- DEF Tank
- Diesel Oxidation Catalyst (DOC)
- Diesel Particulate Filter (DPF)
- DPF Air, Fuel, and Coolant Lines
- DPF Air, Fuel, Manifold Assembly
- DPF Dosing Module
- Exhaust Gas Recirculation (EGR) Valves
- EGR Actuator
- EGR Connecting Bellows and Clamps
- EGR Cooler(s)
- Exhaust Piping, Clamps, and Gaskets
- Exhaust Throttle Valve
- Hydrocarbon Doser Injector (HC Doser, 7th Injector, ARD, AHI Module)
- Hydrocarbon Doser Valve - Air, Fuel, and Coolant Lines; and Inline Air Filter
- Hydrocarbon Doser Valve (Voss Valve)
- Selective Catalytic Reduction (SCR) Catalyst
- SCR Decomposition Pipe and Pipe Elbows
- Sensor, BPV Pressure
- Sensor, Delta P (DPF Pressure)
- Sensor, DOC Inlet Pressure
- Sensor, DOC (Post) Temperature
- Sensor, DOC (Pre) Temperature
- Sensor, DPF Air Supply Pressure
- Sensor, DPF Back Pressure
- Sensor, DPF Fuel Pressure
- Sensor, Lambda (O₂ Sensor)
- Sensor, NOx (2)
- Sensor, Pressure After Exhaust Throttle Valve
- Sensor, SCR (Post) Temperature
- Sensor, SCR (Pre) Temperature
- Wiring Harness - Emission Systems (including overlay)

NEW Comfort Package

The Comfort Package covers components in the engine compartment that keep you comfortable in the cabin.

Covered Components:

- Alternator
- Charge Air Cooler
- Engine Air Compressor
- Fan Clutch
- Fuel Tanks, Cap & Valve
- HVAC Air Compressor & Pulley
- HVAC Blower Motor & Resistor
- HVAC Fan Hub
- HVAC Heater Core
- HVAC Temperature Controls, Control Head & Control Valves
- Radiator & Radiator Cap
- Radio
- Starter & Starter Solenoid

Comfort Package must be purchased with an equipment warranty program

RAPID REPAIR GUARANTEE

No other warranty company offers a guarantee on getting you in and out of the repair facility when you need service.

As part of the *PREFERRED* warranty program we guarantee that your truck will be back on the road in a timely manner, or we'll make your truck's monthly finance payment. See program details on our website.

Eligibility

- Program available to any Class 8 vehicle with less than 1,000,000 miles (on odometer or ECM), whichever is greater

Underwriting

- There is a 30-day waiting period following the month of enrollment



Since 1983, our mission has been to keep you and your truck on the road and moving. That's why we are always designing the industry's best warranty programs to protect your most important asset. And when you need us, we'll be there to provide outstanding customer service to get you back on the road as quickly and safely as possible.

Questions and Claims:

Email: Claims@ntp-p2k.com

Call: 877-950-3200

Web Portal: ntpwarranty.com/portals
ntpwarranty.com



For more information on the NTP *PREFERRED* Warranty program for Owner Operators of United Road, call or email us. A Hylant representative will be happy to tell you more and sign you up for an NTP warranty that fits your business.

260-969-3923

urmarketing@hylant.com

HYLANT